

# RMBF FITTING INSTRUCTIONS

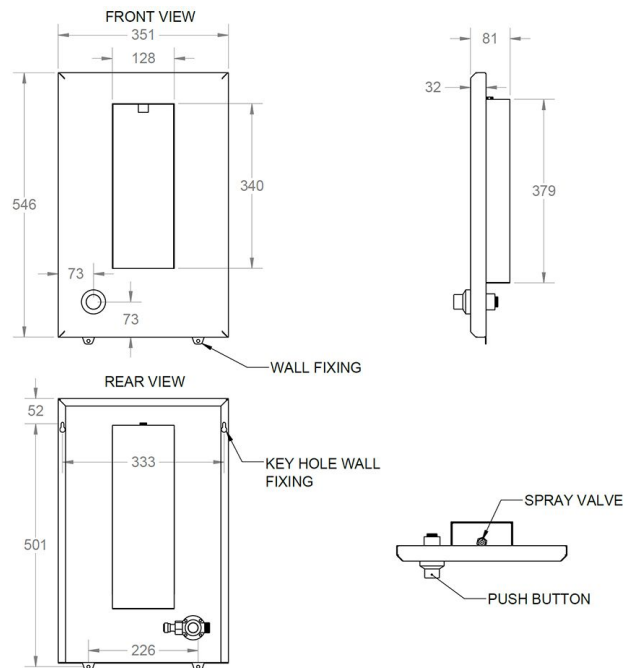

Picture of rear of unit (surface mounted unit shown).

Cut out required in wall to accommodate bottle filling recess, waste pipework and inlet pipework.

The unit fixes to the wall via the two top keyhole slots and two bottom lugs (fixings will need to be purchased to suit your wall type)

There is a 15mm compression fitting required to the water inlet side of the valve. Your water supply will need to be connected here. The compression nut and olive can be removed and a flexible pipe connected if required (by installer). An isolating valve should be fitted to your incoming supply pipework. We recommend fitting a Y strainer to the inlet pipework and all pipework should be flushed before connecting to the unit.

The waste fitting is pre-fitted and has a 32mm flexible waste pipe to allow easy fitting to the buildings waste pipework (a trap should be fitted to your pipework).

Check all connections are watertight.

Clean unit with warm soapy water and a cloth or stiff bristle brush. Further cleaning should be regularly undertaken with soapy water only. Chemical cleaners are not required or advised.



Keyhole fixings at top rear of unit.