

General Stainless Steel Sluice Sink Installation Guidelines

General Sluice Sink Installation Instructions

Stainless steel sluice sinks should be installed on a solid flat wall at an appropriate height to suit the age range of the users. As a general guide 850mm from floor to the top front edge of the sluice sink appears to be a popular choice.

Sluice sinks are made up of a conical bowl with a 4" (100mm) outlet and a full flushing rim very similar to a traditional toilet. The waste is flushed down the outlet by water from the flushing rim. The 4" outlet will need to be connected to a 4" soil pipe and the flushing rim will require connecting to a manual flushing cistern.

There are 4 basic types and styles of sluice sink:

Model DUFS - is a floor standing sluice sink 600 x 600mm supplied as standard with a hinged bucket grating, removable access panel and wall fixing flanges.

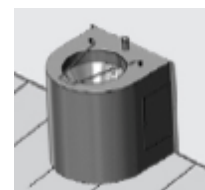

Model DU - is a wall mounted sluice sink 600mm x 600mm, supplied as standard with an anti drip edge to all four sides, and wall fixing brackets, with optional front support legs. Manufactured to comply with the requirements of HTM64: Sanitary Assemblies (2006).



Model DUH - is a wall mounted sluice sink 1000 x 600mm with the sluice sink at one end and a plain top at the other end, supplied as standard with an anti drip edge to all four sides, and wall fixing brackets, with optional front support legs. Manufactured to comply with the requirements of HTM64: Sanitary Assemblies (2006).

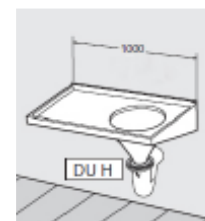

Model DUHS - is a wall mounted sluice sink 1600 x 600mm, with the sluice sink at one end, a sink bowl in the middle and a plain top at the other end, supplied as standard with an anti drip edge to all four sides, and wall fixing brackets, with optional front support legs. Manufactured to comply with the requirements of HTM64: Sanitary Assemblies (2006).



Flush Pipe Connections

There are two choices of connections available on the sluice sink:

Top entry flush pipe connection for use with an **exposed** cistern mounted on the face wall directly above the sluice sink.

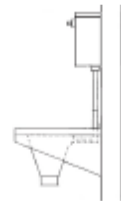

Back entry flush pipe connection for use with a **concealed** cistern mounted in a duct directly behind the sluice sink.

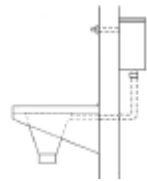

Choice Of Cisterns

There are 3 types of flushing cisterns:

Stainless steel **exposed** surface mounted cistern, complete with stainless steel flush pipe, chrome plated front operating lever, syphon, ball valve and float, and side entry inlet connection.

Cistern size is 500mm wide x 310mm high x 195mm deep.



White plastic exposed surface mounted cistern, complete with stainless steel flush pipe, chrome plated front operating lever, syphon, ball valve and float, and side entry inlet connection.

Cistern size is 505mm wide x 316mm high x 146mm deep.



Black plastic concealed cistern, complete with plastic flush pipe, chrome plated through wall front operating lever, syphon, ball valve and float, and side entry inlet connection.

Cistern size is 505mm wide x 285mm high x 146mm deep.



Unpack your sluice sink and check the items for any damage, missing or incorrectly supplied or ordered items before you start the installation.

Fixing Brackets to Sluice Sink

Remove the protective film from the two wall brackets and secure the brackets to the underside of the sluice sink through the holes in the underneath of the sides with the screws provided (doesn't apply to the DUFS floor standing unit).

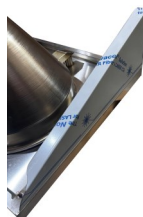

Fixing Sluice Sink To Wall

All sluice sinks should be installed level from side to side and front to back. There are two fixing holes in the rear of each wall bracket, these should be used to screw / bolt the sluice sink to the wall at the appropriate height. The correct wall fixings will need to be used for the type of wall on site (wall fixings are not supplied with the unit for this reason).

Floor standing (DUFs) sluice sinks sit on the floor and attach to the wall by screwing / bolting through the outward flanges on both sides.

Front Support Legs

If front support legs have been purchased there is an M8 stud at the front of the wall brackets to attach the front legs, the legs screw on to the studs and the adjustable foot can be screwed into the floor when the correct height has been set. The legs will need to be fitted to the studs before the wall brackets are fully tightened to the wall.

Water Trap

There are two types of 110mm diameter water traps. P Trap with a horizontal outlet and S Trap with a vertical outlet.

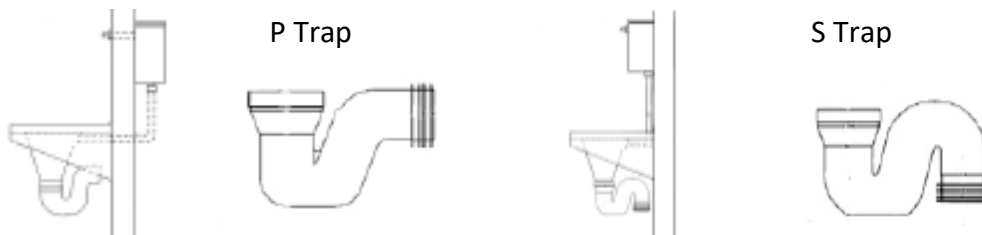

Both styles of trap (if purchased) push onto the 100 mm outlet spigot on the sluice sink and the other end will push into your 100-110mm building waste pipework.

Downpipe Connection

Top entry for exposed cistern—our top entry sluice sinks are supplied with a 38mm stainless steel flushpipe and O ring to seal the flushpipe into the spigot at the top of the sluice bowl. The O ring which is delivered attached to the side of the downpipe should be carefully placed inside the recess in the top entry spigot on the sluice sink. The stainless steel downpipe has a smaller diameter at the bottom to fit into the spigot. The bottom of the downpipe and the O ring in the spigot should be lubricated with washing up liquid or similar and the downpipe carefully inserted keeping it horizontal at all times. The downpipe should slide in until fully inserted.



Back Entry for concealed cistern -There is a 55mm diameter back entry inlet connection to the rear underneath of the sluice sink. The plastic 38mm downpipe supplied with the concealed cistern (if purchased) fits into the connection with the use of a plastic / rubber wc inlet connector that is supplied fitted to the inlet of all of our sluice sinks.



Taps and Waste Fitting For DUHS Units

For DUHS units a 38mm flush grated waste fitting is supplied. This will need to be assembled to the waste hole in the sink unit and connected to a suitable 38mm water trap and then to the buildings waste pipework.

If any taps have been purchased these will need to be fitted following the installation instructions included with the taps.

Cisterns

Instructions for the flushing cisterns are included with all / most of our cisterns and the generic plastic concealed and exposed cistern instructions are at the end of these instructions.

When the cistern is installed and connected the unit and cistern should be checked for correct function and any leaks.

Disclaimer

Washware Essentials continue to pursue a policy of constant product improvement and development. We reserve the right to alter and improve all products without prior notice. Products may therefore differ slightly in specification or visual effect from those illustrated. The information provided is for general guidance only and does not constitute professional advice and is subject to change. We recommend that all installations are undertaken by a professional qualified plumber / electrician, and it is the installers responsibility to ensure the installation meets the relevant guidelines and regulations.

Slimline & Mirage

CISTERN INSTALLATION INSTRUCTIONS

Dudley cisterns are designed to be fixed flat to the wall with suitable rust resistant screws (not supplied) using the holes provided. Cisterns can be fitted for right or left hand operation.

WARNING

No sealing compound, paste, flux, silicone or solvent to be used in contact with plastic or rubber surfaces, to avoid damage to plastic components. Rubber washers should provide adequate seal. PTFE tape may be used on threads. Do not overtighten plastic nuts. No chemical block/additive to be used in this cistern.

Before fixing the cistern to the wall, it is advisable to fit the cisterns internal components...

1 INSTALLATION INSTRUCTIONS

Important: The cistern is factory set to deliver a full flush of 6 litres (4 litres in some specifications). 6 litre flushing is the maximum permissible flush for new WC installations. 6 litre cisterns are capable of being set up to deliver a 6 or 7 litre full flush (**Fig. 1**). Flush volumes above 6L and the upper waterline marked 9L should only be used for retrofit applications to older WC installations. 4 litre flushing should only be used for WC pans specifically designed for that purpose. To convert a dual flush syphon to single flush see section 2 overleaf.

Syphon Installation

Install the syphon with its rubber sealing washer inside cistern. Secure with 1 1/2" BSP back nut. Before fixing the cistern to the wall, it is advisable to fit the remainder of all internal components. Insert flush bend into tail of syphon with the cap nut & rubber compression ring in place. Hand tighten the cap nut. Depending on the height of the cistern from the floor, it may be necessary to cut the flush pipe. Remove traces of burr. No more than 50mm (2") of flush pipe to be inserted into the syphon down leg. (**Fig. 2**).

Ball Float Valves

Bottom and side entry types are fitted with 3mm (1/8") bore high pressure seats (white) to suite mains water supply. A low pressure 6mm (1/4") bore seat (red) is also provided for use only when the cistern is fed from a low pressure supply i.e. a storage tank. Screw ball float onto the end of the arm before fitting valve. Set float position after fitting in to cistern if it is fitted with a swivel arm. (**Fig. 3**).

Side Entry

Screw a spigot nut onto the tail with spigot side facing inwards. Locate the valve tail through the cistern wall. Tighten the second spigot nut with spigot facing towards the cistern to centralise valve in hole. (**Fig. 4**).

Pedestal Bottom Entry

Locate the pedestal float valve tail through the base of the cistern with rubber sealing washer on the inside. Secure using spigot nut facing inwards to locate the pedestal centrally in the cistern hole. Position pedestal to ensure free movement of the float arm. Trim the bracing stay so that it touches the cistern wall and tighten spigot nut. (**Fig. 4**).

Important: Make certain that the float arm moves freely in a vertical path and does not contact other internal components. Position the overhead discharge elbow (**Fig. 3**) so that it is not directed into the reservoir of the syphon. (**Fig. 3**).

Equilibrium Inlet Valves

Follow the instructions supplied with the inlet valve.

Important: For T88 syphon specifications the equilibrium valve and lever assembly should not be fitted on the same side of the cistern.

Water Level

Adjust the inlet valve float arm with the adjusting screw and lock nut or the float on the equilibrium inlet valves. So that the valve shuts off at the required marked water line. Re-check and adjust if necessary. (**Fig. 4**).

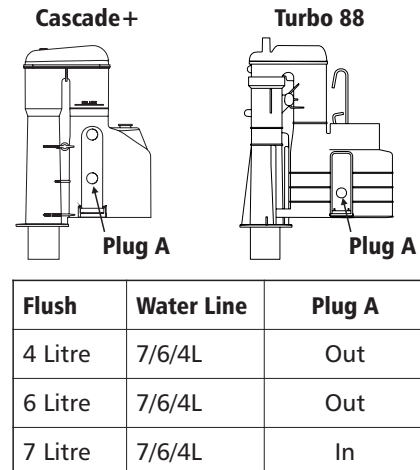

Fig 1

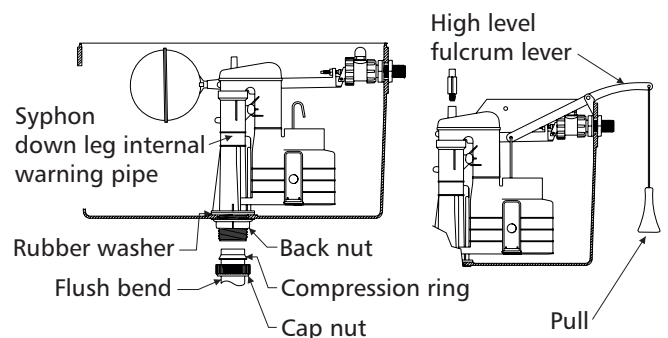

Fig 2

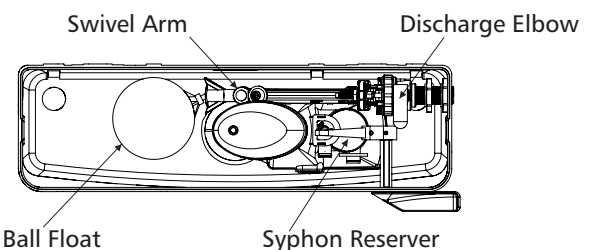

Fig 3

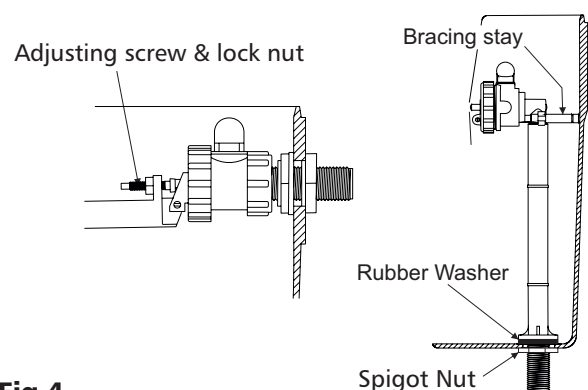

Fig 4

1 INSTALLATION INSTRUCTIONS - CONTINUED

Blanking Plugs

Fit a blanking plug to seal off the unused cistern inlet holes. Press badge or plug into unused lever holes. (Fig. 5).

Overflow Warning

The cistern is supplied with an internal overflow warning that discharges directly into the WC pan. (Fig. 2).

Lever Assembly

Install the operating lever through the cistern lever hole. Secure the lever with back nut. Connect 'C' link to the lift arm, then slide the lift arm onto the square lever shaft and tighten the securing screw. Ensure that the lift arm is in line with the 'C' link and syphon piston rod. Check for correct operation of the lever assembly. (Fig. 6).

High Level Cisterns Only

Attach the fulcrum lever to the 'C' link. Fit the fulcrum lever bracket into the cistern dovetail slot. Secure with screw and nut supplied, then attach the lever pull (Fig. 2). To accommodate the fulcrum lever, cut a slot in the thin section at the end of the cistern lid.

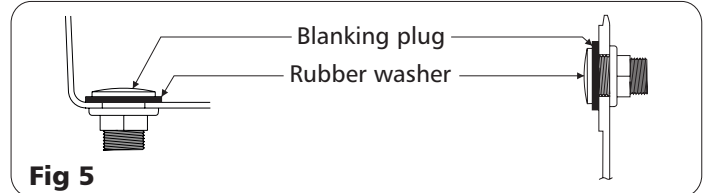

Fig 5

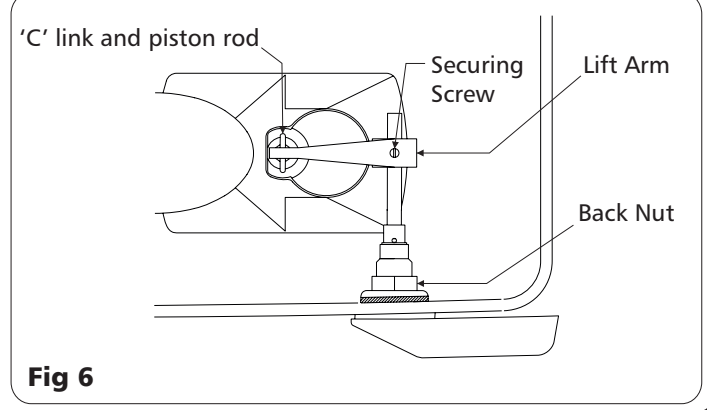

Fig 6

2a SINGLE FLUSH CONVERSION: TURBO 88

Dual flush syphons are capable of being converted to deliver a single flush by following the steps below.

- 1 Remove splash cover, C-link, blue washer and rubber washer from the piston rod and remove the piston assembly.
- 2 Fit the rubber conversion washer (supplied) onto the diaphragm retainer.
- 3 Reassemble the piston assembly and refit to the syphon.

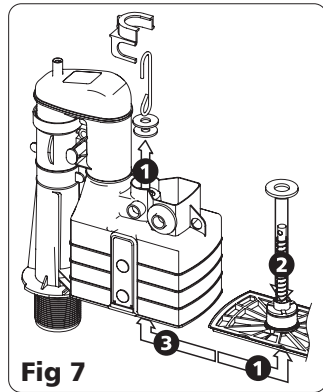

Fig 7

2b SINGLE FLUSH CONVERSION: CASCADE+

Dual flush syphons are capable of being converted to deliver a single flush by following the steps below.

- 1 Remove C-link, washer and O-ring from the piston rod and remove the piston assembly.
- 2 Fit the mono washer (supplied) onto the diaphragm retainer.
- 3 Reassemble the piston assembly and refit to the syphon.

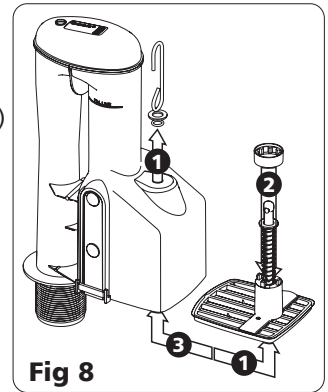

Fig 8

3 FITTING THE CISTERN LID

Fitting the Lid

It is essential that the lid is securely fitted to the cistern with the screw provided. Attach the lid fix extension(s) where provided and secure to the syphon cap. Fit the lid and secure the lid fix screw through the cistern lid into the extension piece.

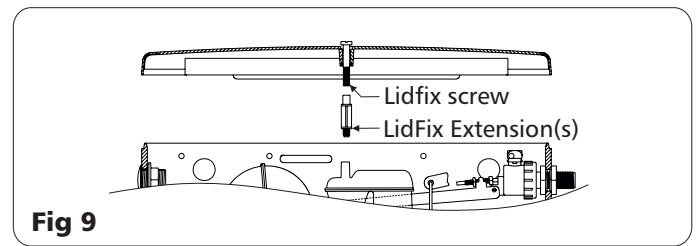

Fig 9

4 FINAL CHECK LIST

Before turning on water supply check the following:

- 1 CISTERN IS SECURE
- 2 ALL MOVING COMPONENTS OPERATE FREELY
- 3 ALL JOINTS ARE TIGHTENED CORRECTLY

Now fill the cistern, set the water level and check the following:

- 4 CHECK CAREFULLY FOR LEAKS
- 5 ENSURE ALL MOVING COMPONENTS OPERATE FREELY
- 6 CHECK FLOAT ARM MOVES FREELY UP & DOWN AND CLOSSES OFF CORRECTLY
- 7 TEST THE SYPHON OPERATION AND THAT THE CISTERN FLUSHES CORRECTLY

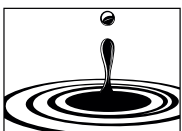

Dudley
Water saving solutions

Thomas Dudley Ltd
P.O.Box 28, Birmingham New Road, Dudley, West Midlands, DY1 4SN

Telephone: 0121 557 5411 E-mail: sales@thomasdudley.co.uk

© 2019 Thomas Dudley Ltd | R334041 14187 iss E